



# Standard Practice for Installation of Ceiling Suspension Systems for Acoustical Tile and Lay-in Panels in Areas Subject to Earthquake Ground Motions<sup>1</sup>

This standard is issued under the fixed designation E 580/E 580M; the number immediately following the designation indicates the year of original adoption or, in the case of revision, the year of last revision. A number in parentheses indicates the year of last reapproval. A superscript epsilon ( $\epsilon$ ) indicates an editorial change since the last revision or reapproval.

*This standard has been approved for use by agencies of the Department of Defense.*

## 1. Scope

1.1 This practice covers the installation of suspended systems for acoustical tile and lay-in panels and their additional requirements for two groups of buildings that are constructed to resist the effects of earthquake motions as defined by [ASCE 7](#) and the [International Building Code](#). These groupings are for Seismic Design Category C and Seismic Design Categories D, E and F.

1.2 The authority having jurisdiction shall determine the applicability of this practice.

1.3 Specification [C 635](#) and Practice [C 636](#) cover suspension systems and their installation without special regard to seismic lateral restraint needs. They remain applicable and shall be followed when this practice is specified.

1.4 This practice is not intended to stifle research and development of new products or methods. This practice is not intended to prevent the installation of any material or prohibit any design or method of construction not prescribed in this practice, provided that any such alternative has been substantiated by verifiable engineering data or full-scale dynamic testing that is acceptable to the authority having jurisdiction.

1.5 Ceiling areas of 1000 ft<sup>2</sup> [92.9 m<sup>2</sup>] or less shall be exempt from the lateral force bracing requirements of [5.2.8](#).

1.6 Ceilings constructed of gypsum board which is screw or nail attached to suspended members that support a ceiling on one level extending from wall to wall shall be exempt from the requirements of this practice.

1.7 Free floating ceilings (those not attached directly to any structural walls) supported by chains or cables from the structure are not required to satisfy the seismic force requirements provided they meet the following requirements:

1.7.1 The design load for such items shall equal 1.4 times the vertical operating weight.

1.7.2 Seismic interaction effects shall be considered in accordance with [5.7](#).

1.7.3 The connection to the structure shall allow a 360° range of motion in the horizontal plane.

1.8 The values stated in either inch-pound or SI units are to be regarded as standard. Within the text, the SI units are shown in brackets. The values stated in each system are not exact equivalents; therefore, each system shall be used independently of the other. Combining values from the two systems result in nonconformance with the specification.

1.9 *This standard does not purport to address all of the safety concerns, if any, associated with its use. It is the responsibility of the user of this standard to establish appropriate safety and health practices and determine the applicability of regulatory limitations prior to use.*

## 2. Referenced Documents

### 2.1 ASTM Standards:<sup>2</sup>

[C 635](#) Specification for the Manufacture, Performance, and Testing of Metal Suspension Systems for Acoustical Tile and Lay-in Panel Ceilings

[C 636](#) Practice for Installation of Metal Ceiling Suspension Systems for Acoustical Tile and Lay-In Panels

### 2.2 Other Standards:

[ASCE 7](#) Minimum Design Loads for Buildings and Other Structures<sup>3</sup>

[CISCA](#) Recommendations for Direct-hung Acoustical Tile and Lay-in Ceilings, Seismic Zones 0-2<sup>4</sup>

[CISCA](#) Guidelines for Seismic Restraint for Direct Hung Suspended Ceiling Assemblies, Seismic Zones 3 & 4<sup>4</sup>  
[International Building Code](#) <sup>5</sup>

<sup>2</sup> For referenced ASTM standards, visit the ASTM website, [www.astm.org](http://www.astm.org), or contact ASTM Customer Service at [service@astm.org](mailto:service@astm.org). For *Annual Book of ASTM Standards* volume information, refer to the standard's Document Summary page on the ASTM website.

<sup>3</sup> Available from American Society of Civil Engineers (ASCE), 1801 Alexander Bell Drive, Reston, VA 20191 or [www.pubs.asce.org](http://www.pubs.asce.org).

<sup>4</sup> Available from Ceiling & Interior Systems Construction Association (CISCA), 1500 Lincoln Hwy, Suite 202, St. Charles, IL 60174.

<sup>5</sup> Available from International Code Council (ICC), 4051 West Flossmoor Road, Country Club Hills, IL 60478-5795.

<sup>1</sup> This practice is under the jurisdiction of ASTM Committee [E33](#) on Building and Environmental Acoustics and is the direct responsibility of Subcommittee [E33.04](#) on Application of Acoustical Materials and Systems.

Current edition approved Aug. 15, 2009. Published August 2009. Originally approved in 1976. Last previous edition approved in 2009 as E 580 – 09<sup>e1</sup>.

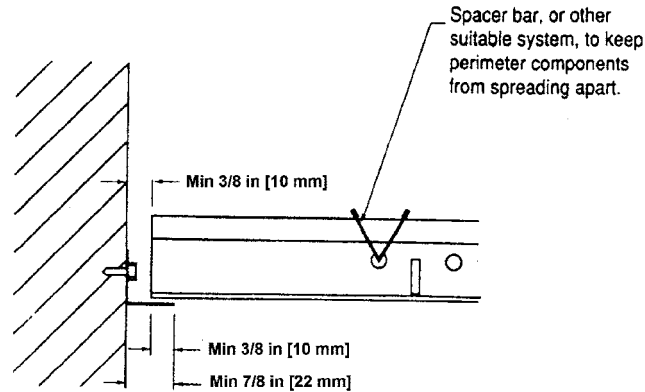

FIG. 1 Category C Treatment of Cross Runners, Main Runners, and Wall Closures at Terminal Ends

NFPA 70 National Electric Code<sup>6</sup>

### 3. Significance and Use

3.1 This practice is a prescriptive set of installation methods to be used for suspended ceilings and is often used in lieu of designing a separate lateral restraint system. The authority having jurisdiction shall determine the applicability of this practice to local code requirements.

3.2 This practice covers installation of suspended ceiling systems and related components in areas that require resistance to the effects of earthquake motions as defined by **ASCE 7** and the **International Building Code**.

3.3 The practice is broken into two main sections. The first section covers areas with light to moderate earthquake potential (Seismic Design Category C) while the second deals with severe earthquake potential (Seismic Design Category D, E & F).

3.4 This practice includes requirements from multiple sources including previous versions of this practice, **CISCA Seismic Recommendations for Direct-hung Acoustical Tile and Lay-in Ceilings, Seismic Zones 0-2** and **CISCA Guidelines for Seismic Restraint for Direct Hung Suspended Ceiling Assemblies, Seismic Zones 3 & 4**, suspended ceiling requirements from the **International Building Code** and **ASCE 7**. The purpose is to combine the requirements from these sources into a single comprehensive document.

### 4. Seismic Design Category C

NOTE 1—This section is intended to provide an unrestrained (free-floating) ceiling system that will accommodate the movement of the structure during a seismic event.

#### 4.1 Suspension System Components:

4.1.1 The recommendations in this section are for ceilings systems with an average weight over the entire ceiling of 2.5 lb/ft<sup>2</sup> [12 N/m<sup>2</sup>] or less. This average weight includes suspension members, panels or tiles, light fixtures, supported flexible

<sup>6</sup> Available from National Fire Prevention association (NFPA), 1 Batterymarch Park, Quincy, MA 02269-9101.

sprinkler drops and air terminals. (See 4.4 and 4.5 for details on lights and mechanical services.) Ceilings with an average weight over the entire ceiling greater than 2.5 lb/ft<sup>2</sup> [12 N/m<sup>2</sup>] shall be installed as specified in Section 5 taking into account the design lateral forces appropriate for Category C. Other deviations or variations shall be substantiated by verifiable engineering data or full-scale dynamic testing.

4.1.2 The main runners and cross runners of the ceiling system and their splices, intersection connectors, and expansion devices shall be designed and constructed to carry a mean ultimate test load of not less than 60 lb [27 kg] in tension and in compression. Allow for a 5° misalignment of the connection in each direction. Instead of a 5° misalignment, the load can be applied with a 1-in. [25-mm] eccentricity on a sample not more than 24 in. [600 mm] long on each side of the splice.

4.1.3 Evaluation of test results shall be made on the mean values resulting from tests on a minimum of three identical specimens. If the deviation of any individual test result exceeds ±10 % from the mean value, three additional samples shall be tested. After the required testing on the six specimens is complete. Drop the high and low test values and use the remaining four test results to obtain the mean test value average. If one of the remaining test results still exceeds the ±10 % mean value, the lowest individual test value recorded from the six test will be used as the reported test result.

#### 4.2 Suspension System Application:

4.2.1 Unless perimeter members meet the structural load carrying requirements and have been approved as a structural part of the system, wall angles or channels shall be considered as aesthetic closers and shall have no structural value assessed to themselves or their method of attachment to the walls.

4.2.2 All perimeter closure angles or channels shall provide a support ledge of 7/8 in. [22 mm] or greater unless the perimeter ends of each cross runner and main runner shall be independently supported as specified in 4.2.1.

4.2.3 When a perimeter closure angle that provides less than 7/8 in. [22 mm] has been approved for use, the perimeter ends of each cross runner and main runner shall be independently

supported within 8 in. [200 mm] from each wall or ceiling discontinuity (see Fig. 3).

4.2.4 The terminal ends of suspension members shall have a minimum of 3/8-in. [9-mm] clearance from the wall as shown in Fig. 1. Reveal (shadow) edge wall closures with these clearances are shown in Fig. 2.

4.2.5 Terminal ends of main runners and cross members shall be tied together to prevent their spreading or have some other approved means to prevent their spreading. Stabilizer bars, cross tees or other means to prevent spreading shall occur within 8 in. [200 mm] of each wall.

4.2.6 Permanent runner end attachment (i.e., pop rivets) for grid alignment purposes shall not be permitted.

4.2.7 All ceiling penetrations (columns, sprinklers, etc.) and independently supported fixtures or services shall have a minimum of 0.375-in. [9-mm] clearance on all sides by using suitable escutcheons or perimeter closure details.

#### 4.3 *Suspension Wire Application:*

4.3.1 Suspension wires that are a minimum of No. 12 gauge [2.70 mm] galvanized, soft-annealed, mild steel wire shall be spaced at 4 ft [1200 mm] on center along each main runner, unless engineering calculations justifying increased spacing are provided.

4.3.2 Each vertical wire shall be attached to the ceiling suspension member and to the support above such that the wire loops shall be tightly wrapped and sharply bent to prevent any vertical movement or rotation of the member within the loops. The wire must be wrapped around itself a minimum of three full turns (360° each) within a 3-in. length. Connection devices to the supporting construction shall be capable of carrying not less than a 100-lb (45-kg) allowable load.

4.3.3 Suspension wires shall not hang more than one in six out of plumb unless countersloping wires are provided.

4.3.4 Wires shall not attach to or bend around interfering material or equipment. A trapeze or equivalent device shall be used where obstructions preclude direct suspension. Trapeze suspensions shall be sized to resist the dead load and lateral forces appropriate for Category C.

#### 4.4 *Light Fixture Application:*

4.4.1 All lighting fixtures shall be positively attached to the suspended ceiling system by mechanical means as specified in the National Electrical Code unless independently supported. The attachment device shall have the capacity of supporting 100 % of the lighting fixture weight acting in any direction. A minimum of two attachment devices are required for each fixture.

4.4.2 Surface-mounted lighting fixtures shall be attached to the ceiling system with a positive clamping device that completely surround the supporting members. Safety wires shall be attached between the clamping device and the adjacent ceiling hanger or to the structure above. In no case shall the fixture exceed the design carrying capacity of the supporting members.

4.4.3 Lighting fixtures weighing less than 10 lb [5 kg] shall have one, No. 12-gauge [2.70 mm] safety wire connected from the fixture housing (not the detachable end plates) to the structure above. It is not necessary for these safety wires to be

taut. Supplementary hanger wires of cross tees supporting light fixtures shall not be required.

4.4.4 Lighting fixtures weighing less than 56 lb [25 kg] shall have, in addition to the requirements outlined in 5.4.1, two No. 12-gauge [2.70 mm] hanger wires connected from the fixture housing to the structure above that act as safety wires. It is not necessary for these safety wires to be taut.

4.4.5 Lighting fixtures weighing 56 lb [25 kg] or more shall be supported directly from the structure above by approved hangers.

4.4.6 Pendant-hung lighting fixtures shall be supported directly from the structure above using no less than No. 9-gauge [3.80 mm] wire or an approved alternate support. The ceiling suspension system shall not provide any direct support.

4.4.7 Rigid conduit is not permitted for attachment of the fixtures.

#### 4.5 *Services within the Ceiling:*

4.5.1 Flexible sprinkler hose fittings, ceiling mounted air terminals or other services weighing less than 20 lb [9 kg] shall be positively attached to the ceiling suspension main runners or cross runners that have the same carrying capacity as the main runners.

4.5.2 Flexible sprinkler hose fittings, air terminals or other services weighing more than 20 lb [9 kg] but less than 56 lb [25 kg] shall have, in addition to the requirements in 4.5.1, two No. 12-gauge [2.70 mm] hanger wires connected from the terminal or service to the ceiling system hangers or to the structure above that act as safety wires. It is not necessary for these wires to be taut.

4.5.3 Flexible sprinkler hose fittings, air terminals or other services weighing more than 56 lb [25 kg] shall be supported directly from the structure above by approved hangers.

#### 4.6 *Partition Application to Suspended Ceilings:*

4.6.1 The ceiling system shall not provide lateral support for walls or partitions. Walls or partitions shall only be attached to the ceiling suspension provided they allow the ceiling membrane to move laterally to accommodate the required clearance as specified in 4.2.4.

## 5. Seismic Design Category D, E & F

NOTE 2—The objective of this section is to provide a restrained ceiling through either connection to the perimeter wall, or through bracing either rigid or non-rigid. The key to good seismic performance of this type of ceiling is that the width of the closure angle around the perimeters are adequate to accommodate ceiling motion and that penetrations, such as columns and piping, have adequate clearance to avoid concentrating restraining loads on the ceiling system.

#### 5.1 *Suspension System Components:*

5.1.1 Only heavy-duty main tees as defined in Specification C 635 shall be used.

5.1.2 The main runners and cross runners of the ceiling system and their splices, intersection connectors, and expansion devices shall be designed and constructed to carry a mean ultimate test load of not less than 180 lb [80 kg] in compression and in tension. The tensile test shall allow for a 5° offset of the connection in any direction. Instead of a 5° misalignment, the load can be applied with a 1-in. [25-mm] eccentricity on a sample not more than 24 in. [600 mm] long on each side of the

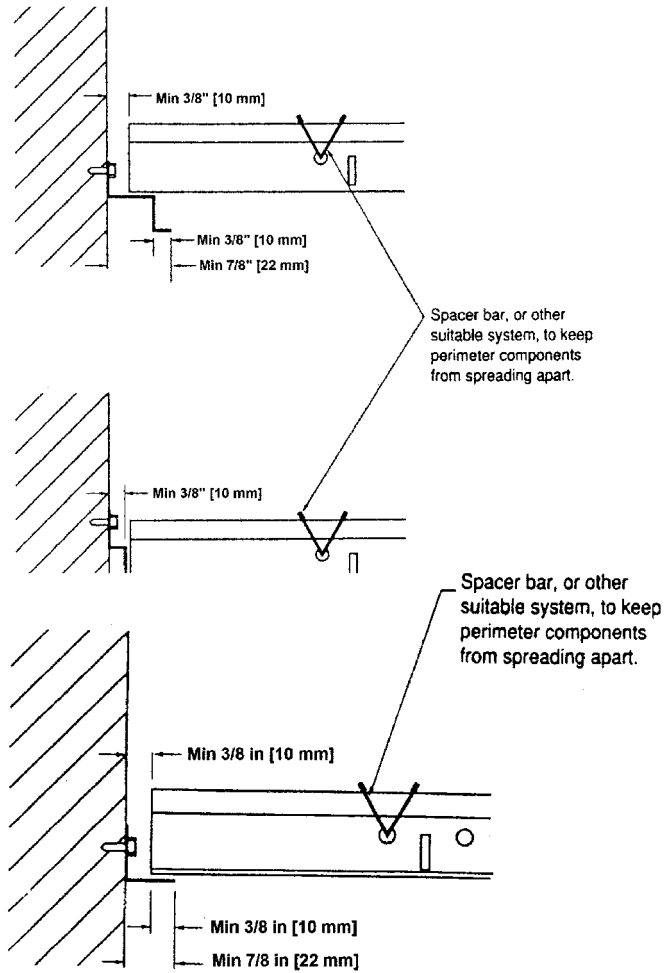

FIG. 2 Category C Treatment of Cross Runners and Main Runners at Terminal Ends When Using Reveal (Shadow) Edge Wall Closures

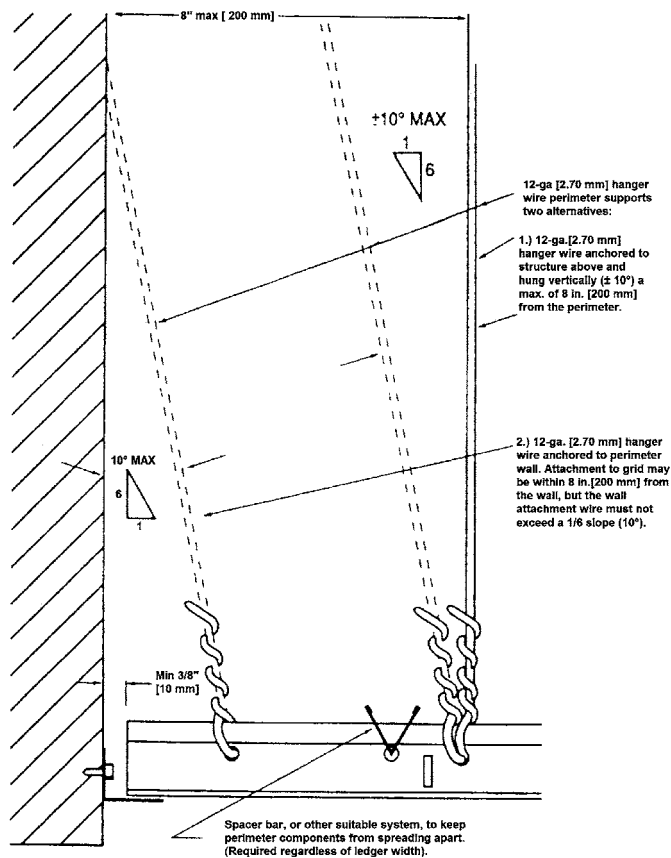

FIG. 3 Category C Treatment of Cross Runners and Main Runners at Terminal Ends When Support Ledge of Perimeter Closure is Less Than Minimum  $\frac{7}{8}$  in. [22 mm]

splice or intersection. The connectors at splices and intersections shall be the mechanical interlocking type.

5.1.3 Evaluation of test results shall be made on the mean values resulting from tests on a minimum of three identical specimens. If the deviation of any individual test result exceeds  $\pm 10\%$  from the mean value, three additional samples shall be tested. After the required testing on the six specimens is complete. Drop the high and low test values and use the remaining four test results to obtain the mean test value average. If one of the remaining test results still exceeds the  $\pm 10\%$  mean value, the lowest individual test value recorded from the six test will be used as the reported test result.

#### 5.2 Suspension System Application:

5.2.1 Unless perimeter members are a structural part of the approved system and meet the structural load carrying requirements, wall angles or channels shall be considered as aesthetic closers and shall have no structural value assessed to themselves or their method of attachment to the walls.

5.2.2 The perimeter support angle shall supply a support ledge of not less than 2 in. [50 mm].

5.2.3 Main runner and/or cross runner ends shall be attached to the perimeter on two adjacent walls. A clearance of  $\frac{3}{4}$  in. [18 mm] shall be maintained between the main runner and cross runner ends and the perimeter members on the two opposite walls (see Fig. 4, C-C). On the walls where the terminal end runners are not fixed to the perimeter supporting closure, allow for  $\frac{3}{4}$  in. [18 mm] axial movement.

5.2.4 Terminal ends of main runners and cross members shall be tied together or have some other approved means to prevent their spreading. Stabilizer bars, cross tees or other means to prevent spreading shall occur within 8 in. [200 mm] of each wall.

5.2.5 Direct concealed suspended ceiling systems shall have positively connected stabilizer bars or mechanically connected cross runners at a maximum spacing of 60 in. [1500 mm] perpendicular to the main runners. Stabilization shall occur within 24 in. [600 mm] of each wall.

5.2.6 The terminal end of each cross runner and main runner shall be supported independently, a maximum of 8 in. (200 mm) from each wall or ceiling discontinuity with No. 12-gauge [2.70 mm] wire or approved wall support. See Fig. 4.

#### 5.2.7 Suspension Wire Application:

5.2.7.1 Suspension wires of galvanized, soft-annealed, mild steel wire shall not be smaller than No. 12 gauge [2.70 mm] spaced at 4 ft [1200 mm] on center along each main runner unless calculations justifying the increased spacing or alternate materials are provided.

5.2.7.2 Each vertical wire shall be attached to the ceiling suspension member and to the support above such that the wire loops shall be tightly wrapped and sharply bent to prevent any vertical movement or rotation of the member within the loops. The wire must be wrapped around itself a minimum of three

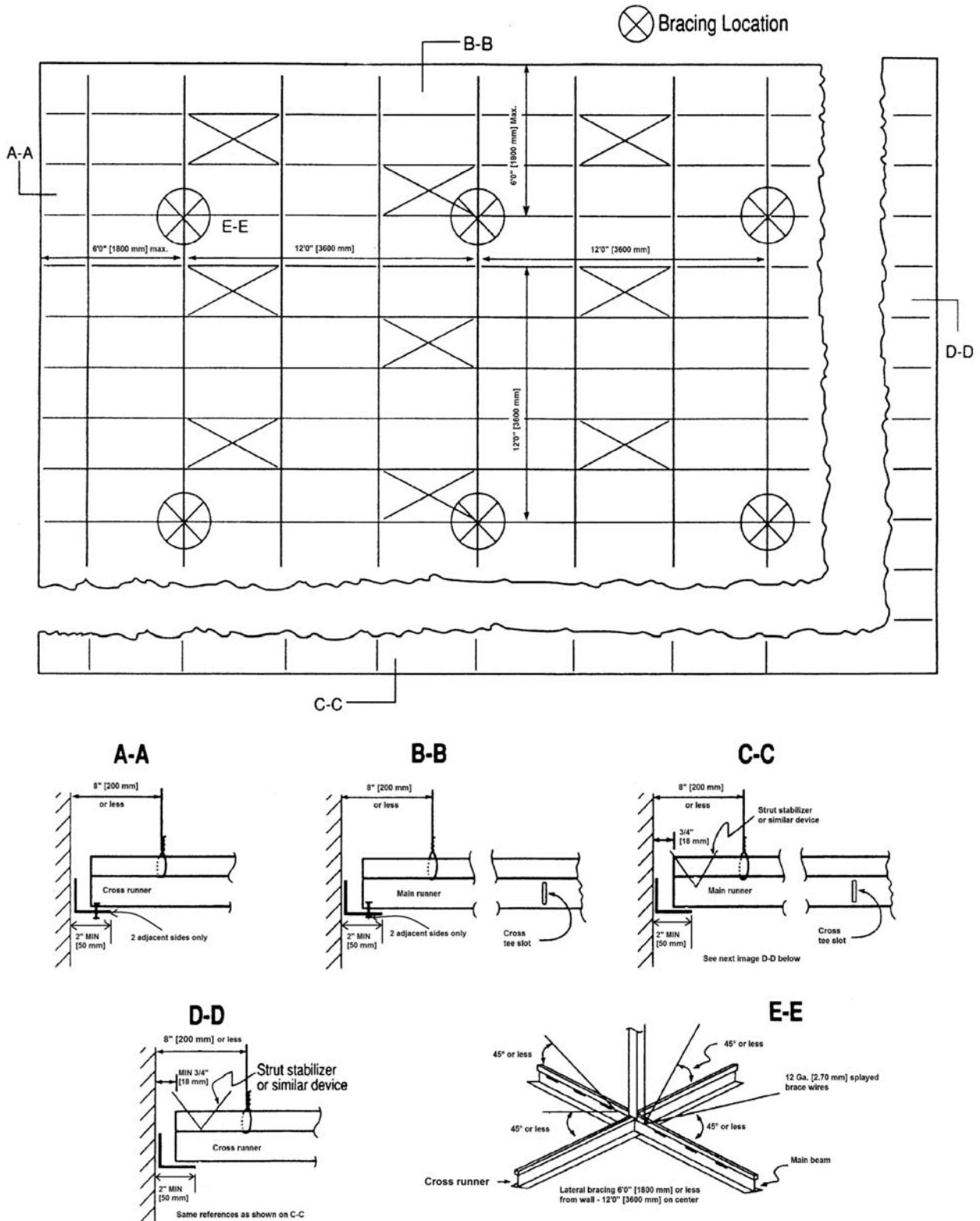

FIG. 4 Categories D, E & F Treatments

full turns (360° each) within a 3-in. [75-mm] length. Connection devices to the supporting construction shall be capable of carrying not less than a 100-lb [45-kg] allowable load.

5.2.7.3 Suspension wires shall not hang more than one in six out of plumb unless countersloping wires are provided.

5.2.7.4 Wires shall not attach to or bend around interfering material or equipment. A trapeze or equivalent device shall be used where obstructions preclude direct suspension. Trapeze suspensions shall be sized to resist the dead load and lateral forces appropriate for the seismic design category.

### 5.2.8 Lateral Force Bracing:

5.2.8.1 Lateral force bracing is required for all ceiling areas greater than 1000 ft<sup>2</sup> [92.9 m<sup>2</sup>].

5.2.8.2 Horizontal restraints shall be effected by four No. 12-gauge [2.70 mm] wires secured to the main runner within 2 in. [50 mm] of the cross runner intersection and splayed 90° from each other at an angle not exceeding 45° from the plane of the ceiling. A strut fastened to the main runner at the location of the bracing wires shall be extended to and fastened to the structural members supporting the roof or floor above. The strut shall be adequate to resist the vertical component induced by the bracing wires. These horizontal restraint points shall be placed 12 ft [3600 mm] on center in both directions with the first point within 6 ft [1800 mm] from each wall. Attachment of the restraint wires to the structure above and to the main runner shall be adequate for the load imposed. See Fig. 4.

5.2.8.3 Lateral force bracing members shall be spaced a minimum of 6 in. [150 mm] from all horizontal piping or duct work that is not provided with bracing restraints for horizontal forces. Bracing wire shall be attached to the grid and to the structure in such a manner that they can support a load of not less than 200 lb [90 kg] or two times the actual design load, whichever is greater.

5.2.8.4 Rigid braces that have been designed to limit relative lateral deflections at the point of attachment of the ceiling grid to less than 0.25 in. [6 mm] are permitted to be used in the place of diagonal splay wires.

5.2.8.5 Except where rigid bracing is used or substantiating design calculations have shown that lateral deflections are limited to less than 0.25 in. [6 mm], sprinkler heads and other penetrations shall have a 2-in. [50-mm] oversize ring, sleeve or adapter through the ceiling tile to allow for free movement of at least 1 in. [25 mm] in all horizontal directions. Alternatively, a flexible sprinkler hose fitting that can accommodate 1 in. [25 mm] of ceiling movement shall be permitted to be used without the oversized ring, sleeve or adapter.

5.2.8.6 Changes in ceiling plane elevation shall have independent positive bracing.

5.2.8.7 Cable trays & electrical conduits shall be supported and braced independently of the ceiling.

5.2.8.8 *Integral Ceiling/Sprinkler Construction*—As an alternate to providing the large clearances specified in 5.2.8.4, it is acceptable for the sprinkler system and the ceiling system grid to be designed and constructed so that they are tied together as an integral unit. Such a design shall be performed by a registered engineer and shall consider the mass and flexibility of all elements involved, including the ceiling system, sprinkler system, light fixtures and mechanical (HVAC) appurtenances.

### 5.2.9 Seismic Separation Joint:

5.2.9.1 All continuous ceiling areas exceeding 2500 ft<sup>2</sup> [232 m<sup>2</sup>], shall have a seismic separation joint, bulkhead braced to the structure or full height partition that breaks the ceiling into areas of no more than 2500 ft<sup>2</sup> [232 m<sup>2</sup>] and having a ratio of the long to short dimension less than or equal to 4. Each area shall be capable of allowing  $\pm 3/4$  in. [18 mm] axial movement. Areas surrounded by bulkheads or full height partitions shall be provided with closure angles in accordance with 5.2.2. Each

area with a seismic separation joint, bulkhead or full height partition shall have horizontal bracing or restraints in accordance with 5.2.8.2.

### 5.3 Light Fixture Application:

5.3.1 All lighting fixtures shall be positively attached to the suspended ceiling system by mechanical means as specified in the National Electrical Code, unless independently supported. The attachment device shall have the capacity of 100 % of the lighting fixture weight acting in any direction. A minimum of two attachment devices are required for each fixture.

5.3.2 Surface-mounted lighting fixtures shall be attached to the ceiling suspension system with positive clamping devices that completely surround the supporting members. Safety wires shall be attached between the clamping device and the adjacent ceiling hanger or to the structure above. In no case shall the fixture exceed the design carrying capacity of the supporting members.

5.3.3 When the load carrying capability of cross tees supporting light fixtures is less than 16 lbs/ft (241.7 N/m), supplemental hanger wires shall be required. Supplemental hanger wires shall be installed as shown in Fig. 5.

5.3.4 Lighting fixtures weighing less than 10 lb [5 kg] shall have one, No. 12 gauge [2.70 mm] safety wire connected from the fixture housing to the structure above. It is not necessary for these safety wires to be taut.

5.3.5 Lighting fixtures weighing greater than 10 lb [5 kg] but less than 56 lb [25 kg] shall have, in addition to the requirements outlined in 5.3.4, two No. 12-gauge [2.70 mm] hanger wires connected from the fixture housing (not the detachable end plates) to the structure above that act as safety wires. It is not necessary for these safety wires to be taut.

5.3.6 Lighting fixtures weighing 56 lb [25 kg] or more shall be supported directly from the structure above by approved hangers.

5.3.7 Pendant-hung lighting fixtures shall be supported directly from the structure above using no less than No. 9-gauge [3.70 mm] wire or an approved alternate support. The ceiling suspension system shall not provide any direct support.

5.3.8 Rigid conduit shall not be used for attachment of the fixtures.

### 5.4 Services within the Ceiling:

5.4.1 Flexible sprinkler hose fittings, ceiling-mounted air terminals or other services weighing less than 20 lb [9 kg] shall be positively attached to the ceiling suspension main runners or to cross runners that have the same carrying capacity as the main runners.

5.4.2 Flexible sprinkler hose fittings, air terminals or other services weighing more than 20 lb [9 kg] but less than 56 lb [25 kg] shall have, in addition to the requirements in 5.4.1, two No. 12-gauge [2.70 mm] hanger wires connected from the terminal or service to the ceiling system hangers or to the structure above that act as safety wires. It is not necessary for these wires to be taut.

5.4.3 Flexible sprinkler hose fittings, air terminals or other services weighing more than 56 lb [25 kg] shall be supported directly from the structure above by approved hangers.

### 5.5 Partition Application to Suspended Ceilings:

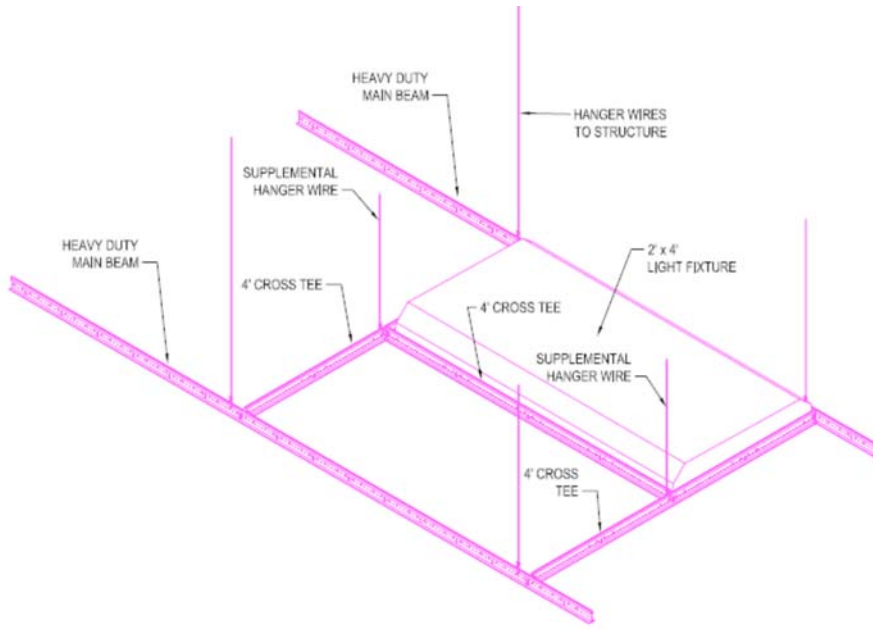

FIG. 5 Supplemental Hanger Wires at Light Fixtures

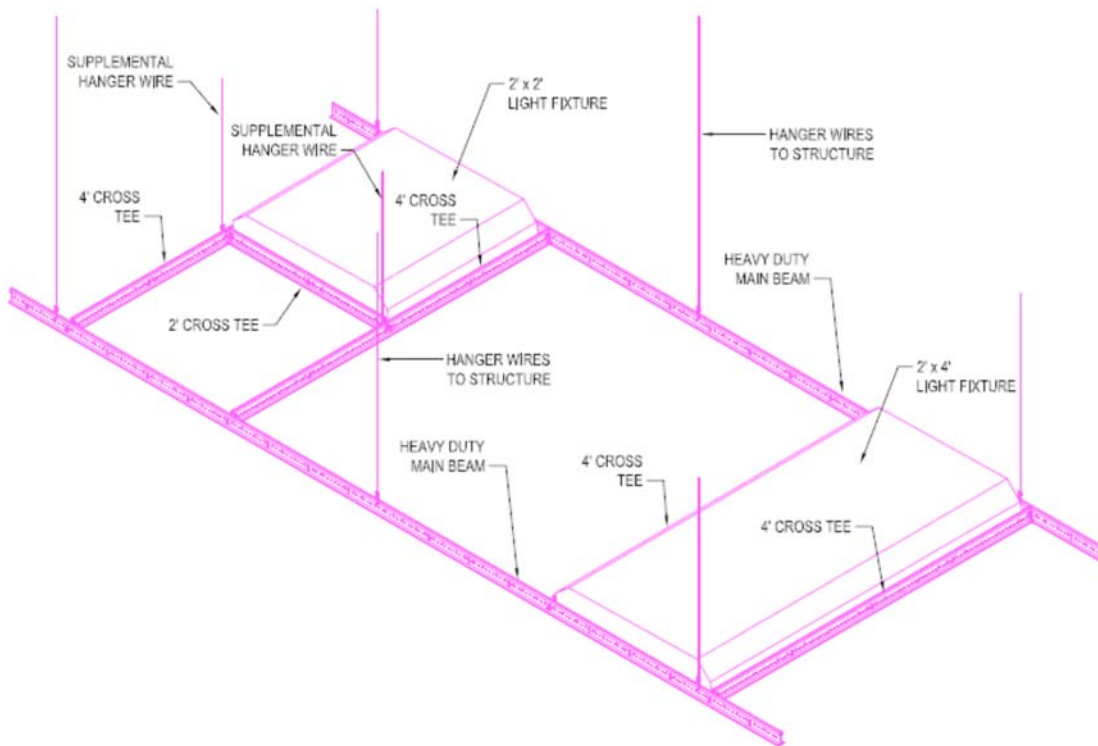

FIG. 5 Supplemental Hanger Wires at Light Fixtures (continued)

5.5.1 Partitions that are tied to the ceiling and all partitions greater than 6 ft (1.8 m) in height shall be laterally braced to the building structure. Such bracing shall be independent of any ceiling splay bracing. Bracing shall be spaced to limit horizontal deflection at the partition head to be compatible with ceiling deflection requirements as determined for suspended ceilings.

5.6 Ceiling Penetrations:

5.6.1 All ceiling penetrations (columns, etc.) and independently supported fixtures or services shall be considered as perimeter closures that also must allow the required clearances by using suitable closure detail.

5.7 Consequential Damage/Seismic Interaction Effects:

5.7.1 The functional and physical interrelationship of architectural components (ceilings), their supports, and their effect on each other shall be considered so that the failure of an



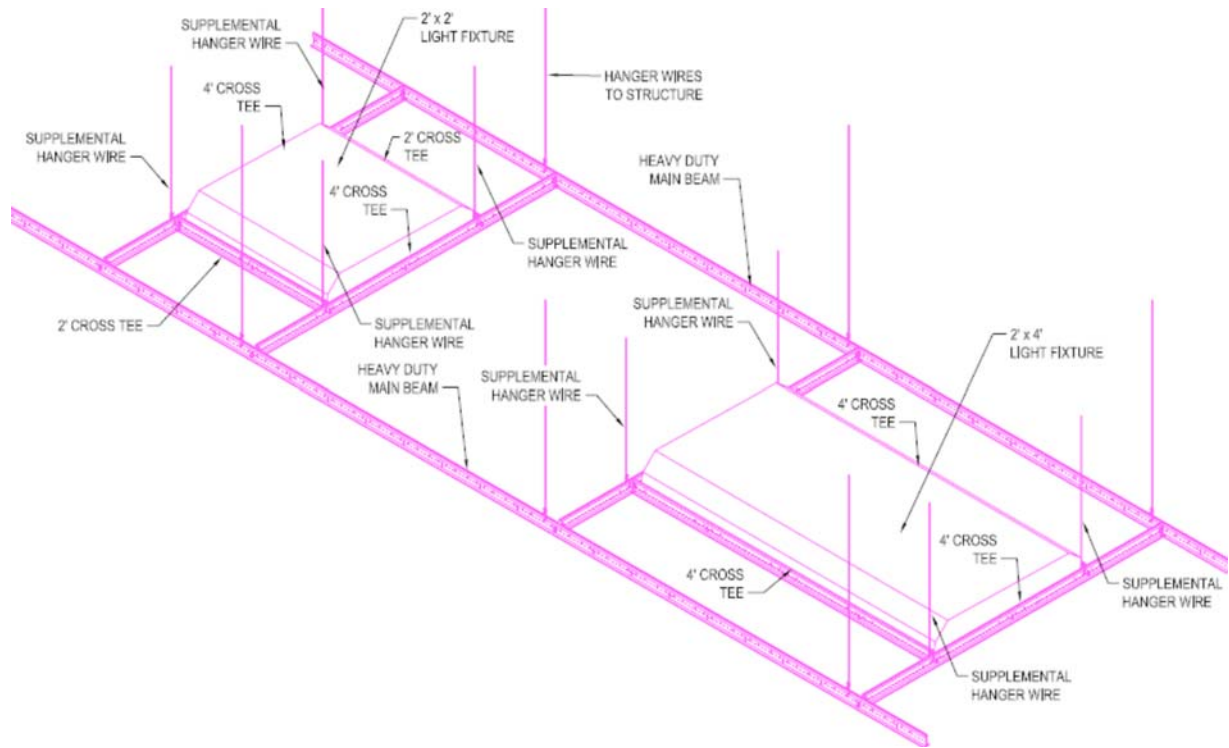

**FIG. 5 Supplemental Hanger Wires at Light Fixtures** (continued)

essential or non-essential ceiling, mechanical or electrical component shall not cause the failure of an essential ceiling, mechanical or electrical component. This shall be the responsibility of the design professional.

NOTE 3—An essential component is a component that must function and be operable immediately after a seismic event.

## 6. Substantiation

6.1 Each ceiling system manufacturer shall furnish tension and compression force capabilities of main runner splices, cross runner connections, and expansion devices. The manufacturer shall also furnish load capabilities of the suspension system components.

6.2 All load testing shall be conducted or witnessed by an approved independent testing agency.

6.3 All seismic ceiling designs not conforming to this standard shall be by a licensed engineer and shall be approved by the authority having jurisdiction.

## 7. Drawings and Specifications

7.1 The drawings shall clearly identify all systems and shall define or show all supporting details, lighting fixture attachment, lateral force bracing, partition bracing, etc. When this standard is referenced in a drawing, this standard shall be considered part of the requirements of the drawing to the prescribed extent of such reference. Where differences occur between provisions of this standard and referenced codes, the provisions of the code shall apply. Deviations or variation shall be shown or defined in detail.

## 8. Keywords

8.1 ceiling suspension; earthquake; seismic; seismic restraint; suspended ceiling

## APPENDIX

## (Nonmandatory Information)

## X1. COMMENTARY

X1.1 Recommendations in previous versions of this practice were based in part on testing done in the 1980's. This, coupled with general observations from the earthquake prone areas in California have lead to the original practice.

X1.2 Actual earthquake experience (most notably Northridge and Loma Prieta earthquakes) has shown that three main things are critical for good performance of ceiling systems during earthquakes which are:

X1.2.1 Independent safety wires on light fixtures to prevent dropout,

X1.2.2 Minimum strength requirements for splices and cross/runner/main runner intersections, and

X1.2.3 Spreader bars and independent support of suspension member terminal ends at wall closures which prevent panel dropout if the perimeter suspension terminal end slips off of the closure support ledge.

X1.3 These observations have lead to the requirement for safety wires on light fixtures and minimum connection

strengths in Practice E 580/E 580M. This also led to the requirement for 2-in. [50 mm] perimeter support ledger and the requirement for independent support of terminal ends of suspension members.

X1.4 Advent of **International Building Code** has raised the awareness of seismic installation requirements in areas within the United States where these requirements traditionally were not a concern.

X1.5 The introduction of non-traditional ceiling made of wood and metal, as well as ceilings that do not use traditional tee bar suspension systems, has lead to a need for an expansion of the prescriptive installation requirements. There has been also a general concern over the interaction of the ceiling system with HVAC components, lights and sprinklers. This coupled with the coming of next generation of performance based seismic codes has lead to new interest in clear and concise requirements for installation of ceiling systems. The result is this current rewrite of this practice.

*ASTM International takes no position respecting the validity of any patent rights asserted in connection with any item mentioned in this standard. Users of this standard are expressly advised that determination of the validity of any such patent rights, and the risk of infringement of such rights, are entirely their own responsibility.*

*This standard is subject to revision at any time by the responsible technical committee and must be reviewed every five years and if not revised, either reapproved or withdrawn. Your comments are invited either for revision of this standard or for additional standards and should be addressed to ASTM International Headquarters. Your comments will receive careful consideration at a meeting of the responsible technical committee, which you may attend. If you feel that your comments have not received a fair hearing you should make your views known to the ASTM Committee on Standards, at the address shown below.*

*This standard is copyrighted by ASTM International, 100 Barr Harbor Drive, PO Box C700, West Conshohocken, PA 19428-2959, United States. Individual reprints (single or multiple copies) of this standard may be obtained by contacting ASTM at the above address or at 610-832-9585 (phone), 610-832-9555 (fax), or service@astm.org (e-mail); or through the ASTM website (www.astm.org).*